

# Bearingless encoders

Resolution 1 ...65536 for Incremental Version

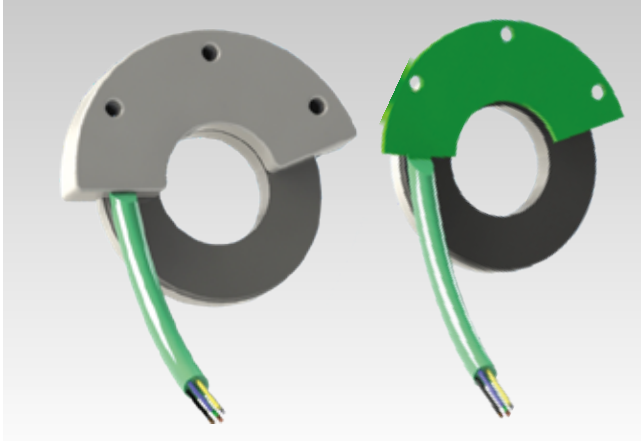

## FNC MAR3015 Series, Incremental Axial



### Features

- Off - Axis Incremental rotary encoder
- Robust mechanical and electrical construction
- Corrosion resistant magnetic ring
- Outer diameter 30 mm
- Inner diameter 15mm
- Up to 65.536 PPR max. for incremental rotary encoder
- <300 kHz frequency
- Magnetic system

### Technical data - electrical ratings

Voltage supply	4.75VDC to 5.5VDC
Protection:	Output short circuit protection. Reverse polarity protection
Consumption w/o load	≤60 mA
Output circuit	Linedriver/RS422 Push-pull short-circuit proof
EMC Standars	EN 61000-6-2 / EN 61000-6-4
Approval	CE

### Technical data - mechanical design

Dimensions (ring)	ø30 mm
Protection DIN EN 60529	IP54, IP65
Operating speed	≤10000 rpm
Matetials	Ring: Aluminum
Operating / Storage temperature	-20...+85 °C / -30°C ...+90°C
Weight approx.	200 g

### Pulse Diagram for Incremental Version

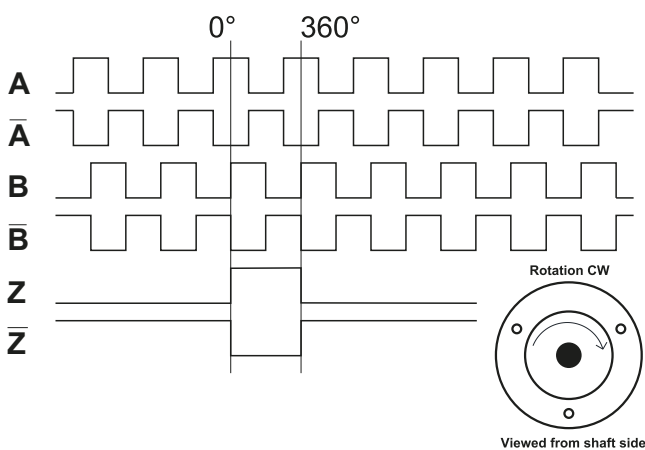

### Cable Wiring

Function	Color
+VB	Brown
GND	White
A	Green
A'	Red
B	Yellow
B'	Pink
Z	Gray
Z'	Blue

# FNC MAR3015 Series, Incremental Axial

### Mechanical dimension

Cover Type, Inner Diameter 4 mm, Screw Mounting

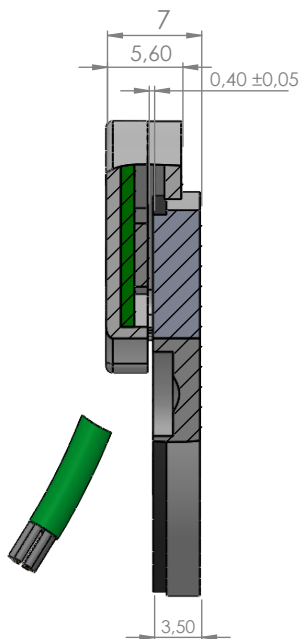
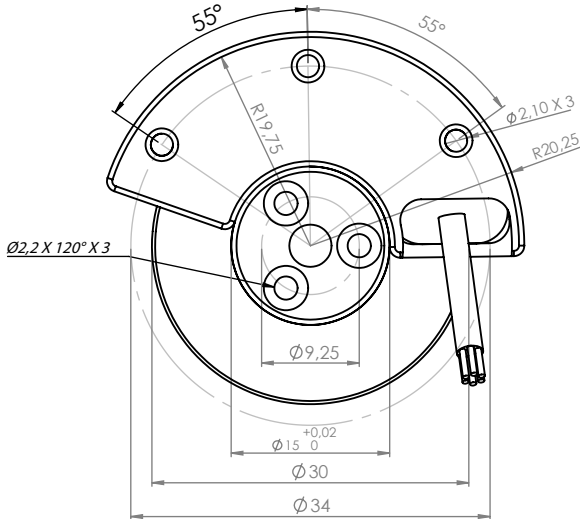

R00/02.06.22

PCB Type, Inner Diameter 4 mm, Screw Mounting

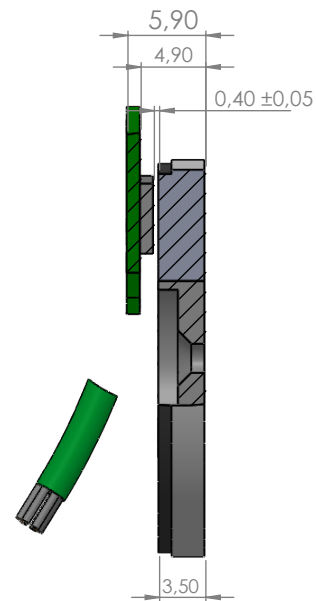
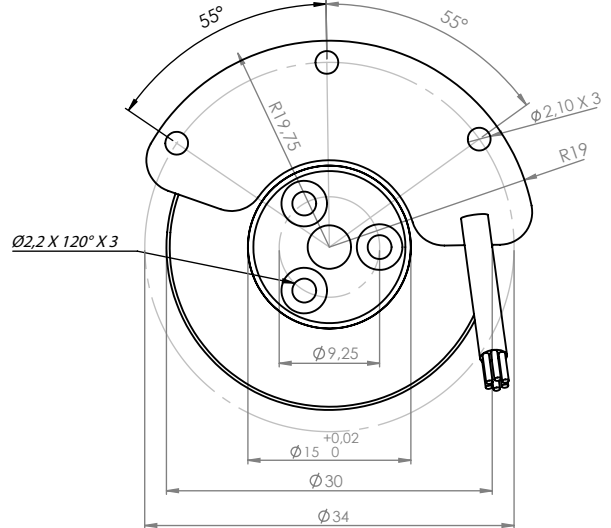

R00/02.06.22

Ring Dimensions, Inner Diameter 4 mm, Screw Mounting

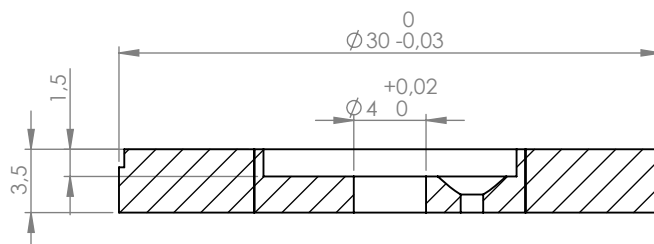
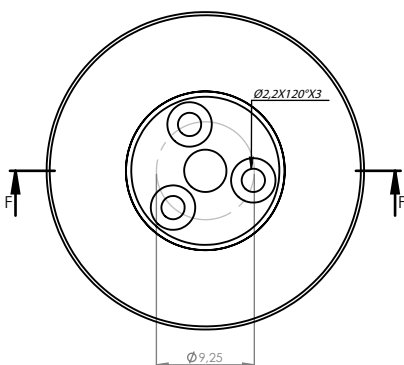

Magnetic Ring Part Number : **FNC MAR1324SM**

## FNC MAR3015 Series, Incremental Axial

### Mechanical dimension

**Cover Type, Inner Diameter 15 mm**

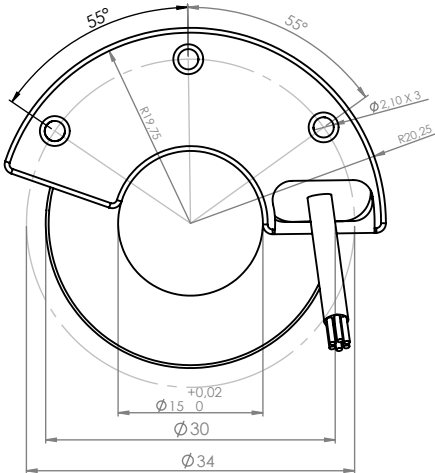

**PCB Type, Inner Diameter 15 mm**

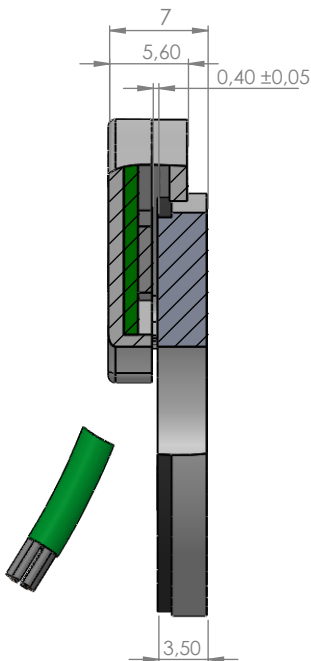
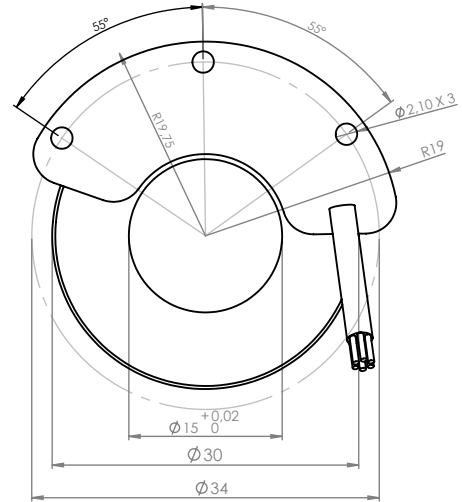

R00/02.06.22

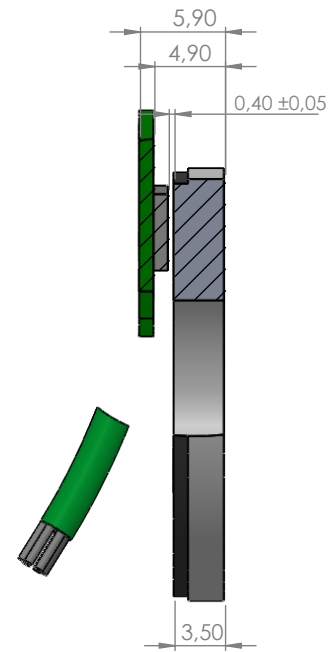

R00/02.06.22

**Ring Dimensions, Inner Diameter 15 mm**

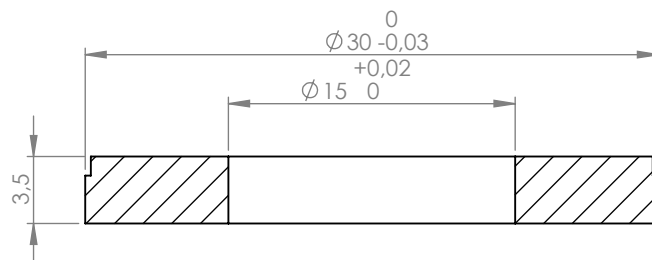
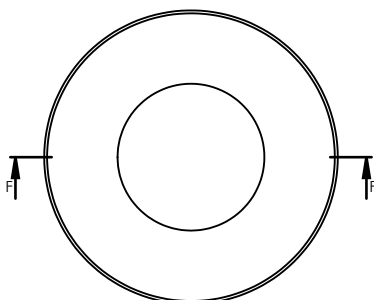

Magnetic Ring Part Number : **FNC MAR13215**

P.S. When the magnet and pcb are positioned correctly, the green led lights up constantly. The red led indicates errors received ( distance, wrong positioned magnet etc.)

### FNC MAR3015 Series, Incremental Axial

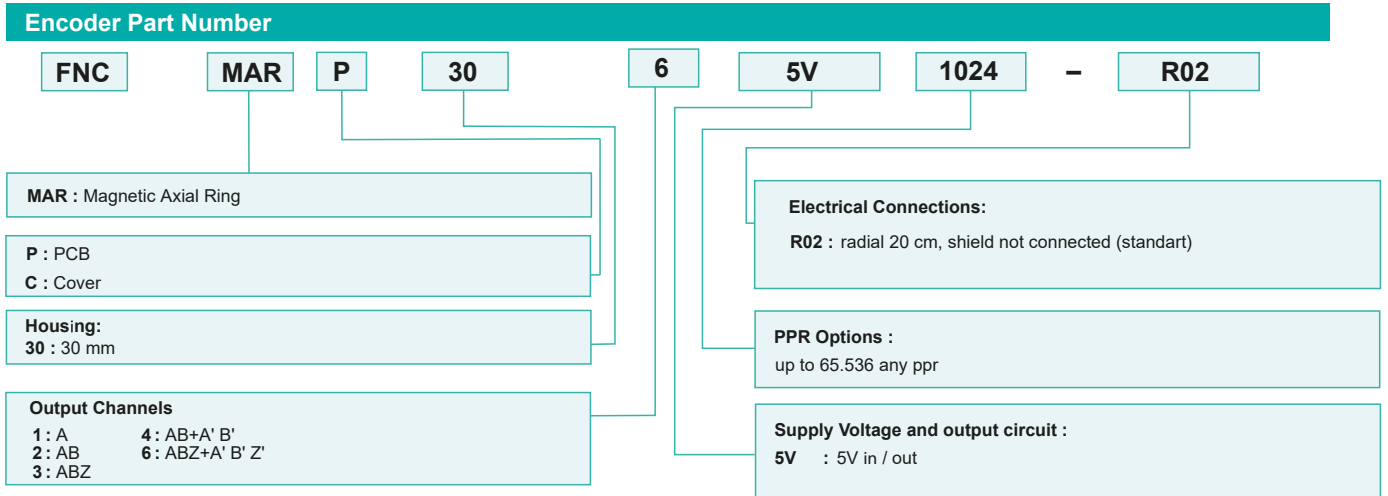

#### Magnetic Ring Part Number, Inner Diameter 15 mm

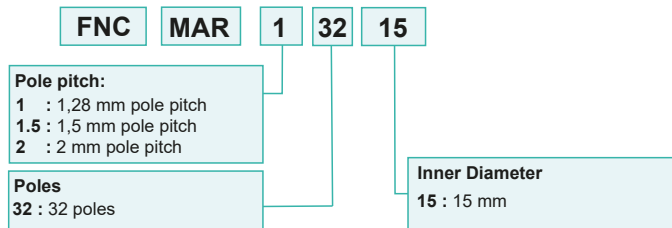

#### Magnetic Ring Part Number, Inner Diameter 4 mm with Screw Mounting

