

Bearingless encoders

Resolution 8 to 18 bit for Absolute Version
SSI / BISS Interface



FNC MAR13590 Series, Absolute Axial

Features

- Off - Axis absolute rotary encoder
- Robust mechanical and electrical construction
- Corrosion resistant magnetic ring
- Outer diameter 135 mm
- Inner diameter 90 mm
- Up to 18 bit for absolute rotary encoder
- <300 kHz frequency
- Magnetic system

Technical data - electrical ratings

Voltage supply	4.75VDC to 5.5VDC
Protection:	Output short circuit protection. Reverse polarity protection
Consumption w/o load	≤60 mA
Output circuit	Linedriver/RS422
EMC Standars	EN 61000-6-2 / EN 61000-6-4
Approval	CE

Technical data - mechanical design

Dimensions (ring)	ø135 mm
Protection DIN EN 60529	IP54, IP65
Operating speed	≤10000 rpm
Matetials	Ring: Aluminum
Operating / Storage temperature	-20...+85 °C / -30°C ...+90°C
Weight approx.	200 g

Cable Wiring

Function	Color
+VB	Brown
GND	White
Clock+	Blue
Clock-	Blue-black
Data+	Orange
Data-	Orange-black

Pulse Diagram for Absolute Version

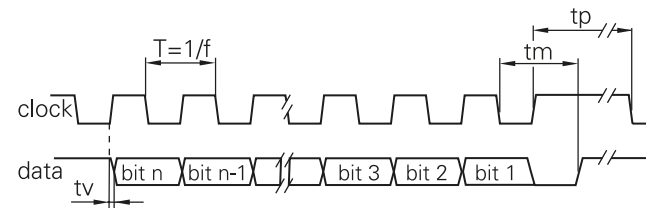

Clock frequency, f	50...2000 kHz for SSI up to 10MHz for BISS
Code	Binary or gray
Status and parity bit	On request
Monoflop time tm	>15µs
Clock timeout	Programmable at factory

Bearingless encoders

Mechanical Dimensions
Cable/Connector Wiring, Part Number



FNC MAR13590 Series, Absolute Axial

Mechanical Dimensions

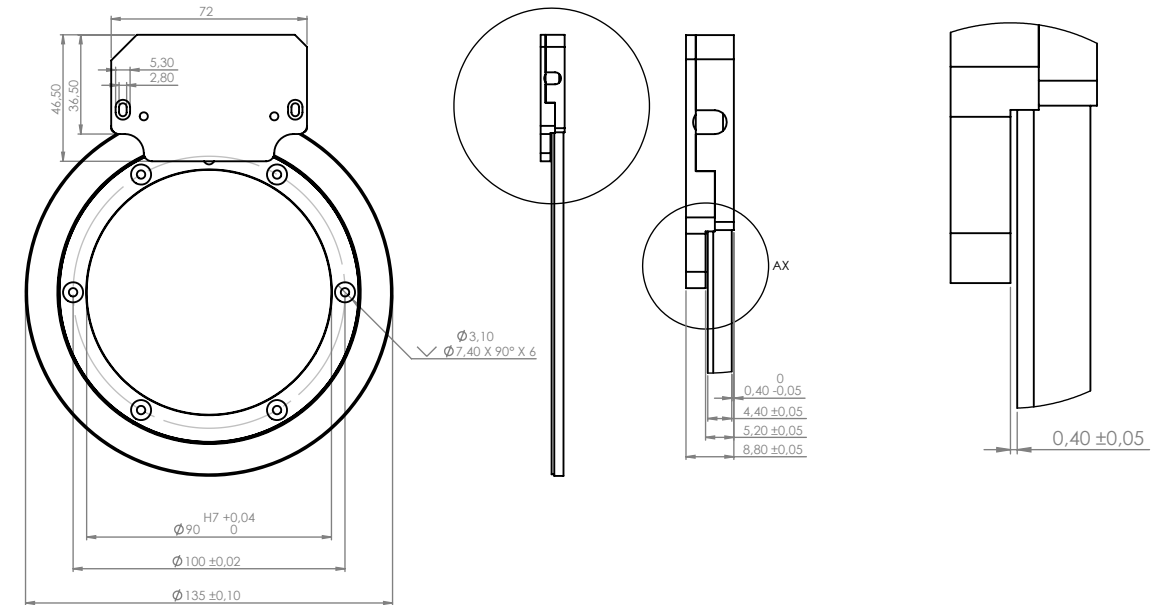

Ring Dimensions

P.S. When the magnet and pcb are positioned correctly, the green led lights up constantly. The red led indicates errors received (distance, wrong positioned magnet etc.)

Encoder Part Number for Absolute Version

