

# Absolute encoders

Singleturn 12...19 bit  
Multiturn 4...32 bit



## FNC AS58S Series



### Features

- Encoder single or multiturn SSI/BiSS
- Magnetic or optical sensing
- Optical singleturn resolution: 12...19 bit
- Magnetic singleturn resolution: 9...13 bit
- Multiturn 4...32 bit
- Servo flange
- Permanent check of code continuity
- Extreme resistance to shock and vibration
- Encoder with electronic reset

### Technical data-electrical ratings

Voltage supply	5.5VDC to 30VDC 4.75VDC to 5.5VDC
Protection	Output short circuit protection. Reverse polarity protection (except 5V version)
Consumption w/o load	≤50 mA (24 VDC)
Interface	SSI or BiSS
Resolution (steps/turn)	Magnetic : 14 bit Optic : 21 bit
Absolute accuracy	Magnetic: ± 0,1° Optic : ± 0,01°
Optoelectronic life time	100,000 (min)
Code	Gray or Binary
Inputs	SSI differential clock Direction (only for magnetic) Electronic zero setting
Output frequency	up to 2 MHz (SSI) up to 10 MHz (BiSS)
Output circuit	SSI data linedriver RS485
Interference immunity	DIN EN 61000-6-2
Emitted interference	DIN EN 61000-6-4
Approval	CE

### Technical data-mechanical ratings

Dimensions (flange)	Ø58 mm
Shaft loading	≤140 N axial ≤240 N radial
Protection DIN EN 60529	IP54, IP65
Operating speed	≤10,000 rpm
Starting torque	≤0.025 Nm (IP67)
Materials	Housing: aluminum Shaft: stainless steel
Shaft diameter	6, 8, 10, 12 mm (other diameters on request)
Bearings lifetime	2x10 <sup>9</sup> rev. at 100% of full rated shaft load (minimum)
Operating temperature	-40...+110°C
Storage temperature	-40°C up to +120°C
Weight approx.	250 g

FNC AS58S Series

Mechanical Dimensions

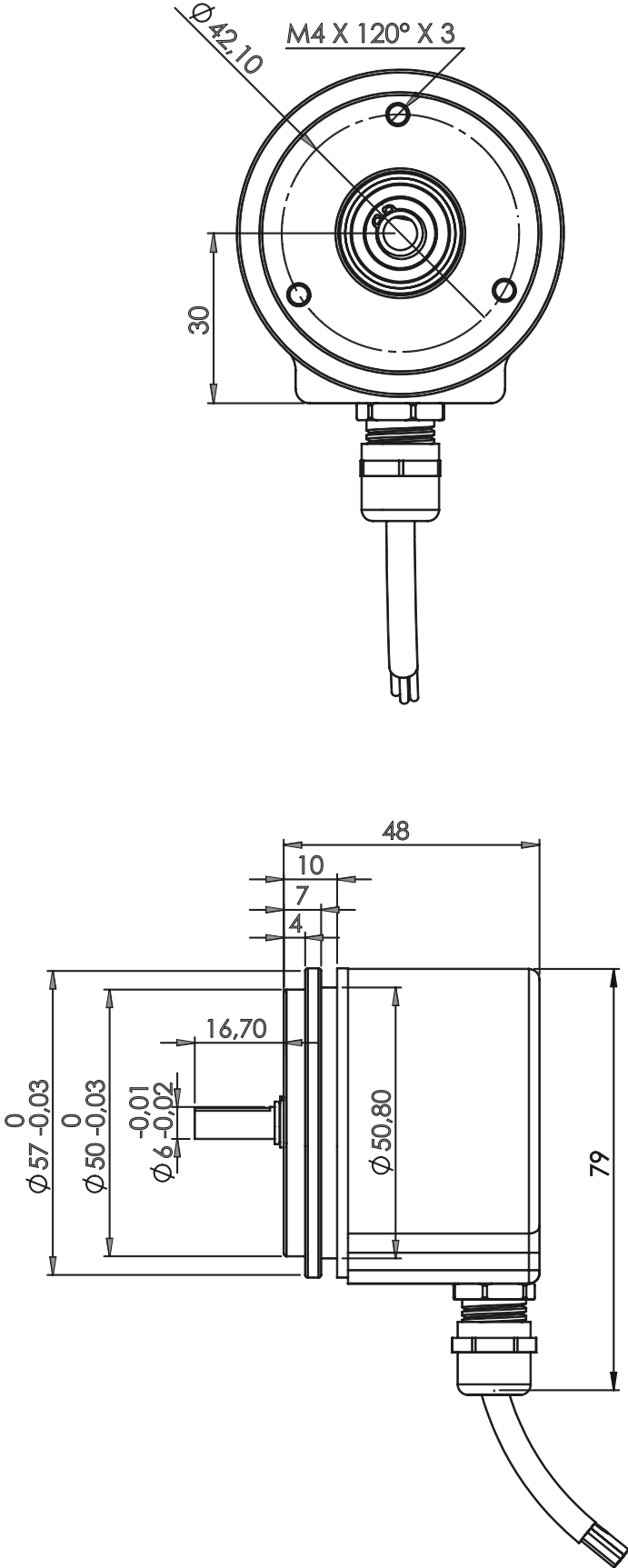







# Absolute encoders

Cable / Connector Wiring, Part Number







## FNC AS58S Series

### Cable Connection

Function	Color	Renk	Farbe	Цвет
+VB	 Brown	Kahve	Braun	Коричневый
GND	 White	Beyaz	Wei	Белый
DATA+	 Orange	Turuncu	Orange	Оранжевый
DATA-	 Orange-Black	Turuncu-Siyah	Orange-Schwarz	Оранжево-черный
CLOCK-	 Blue	Mavi	Gelb	синий
CLOCK+	 Blue-Black	Mavi-Siyah	Gelb-Schwarz	сине-черный
DIRECTION	 Gray-Black	Gri-Siyah	Grau-Schwarz	Серо-черный
PRESET	 Gray	Gri	Grau	Серый
Shield	Black	Siyah	Schwarz	Чернить

### Connector Connection

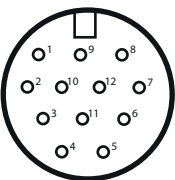
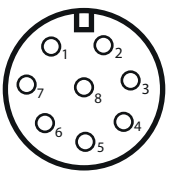
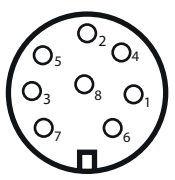
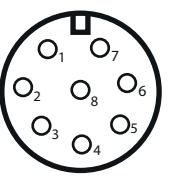
Function	R2312R	R1208	R1508	R1608
+VB	pin 11	pin 5	pin 5	pin 5
GND	pin 12	pin 6	pin 6	pin 6
DATA+	pin 3	pin 3	pin 3	pin 3
DATA-	pin 4	pin 4	pin 4	pin 4
CLOCK+	pin 2	pin 2	pin 2	pin 2
CLOCK-	pin 1	pin 1	pin 1	pin 1
DIRECTION	pin 8	pin 8	pin 8	pin 8
PRESET	pin 9	pin 7	pin 7	pin 7
Connector				
Pin Design				

\*\* for other connector options visit [www.fenac.com.tr](http://www.fenac.com.tr)

# Absolute encoders

## Pulse Diagram, Part Number

### FNC AS58S Series

#### Pulse Diagram

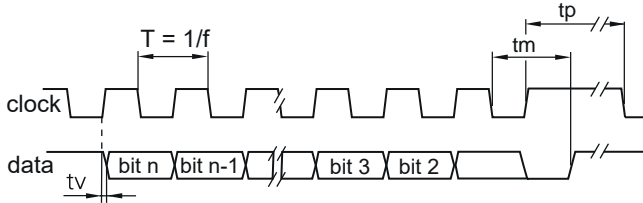

Clock frequency, f	50...2000 kHz for SSI up to 10 MHz for BiSS
Code	Binary or Gray
Status and parity bit	On request
Monoflop time $t_m$	>15 $\mu$ s
Clock time out	Programmable at factory

#### Terminal Significance

+Vs	Encoder supply voltage
0 V	Encoder ground connection relating to +Vs
Data+	Positive data output.
Data-	Negative data output.
Clock+	Positive SSI clock output.
Clock-	Negative SSI clock output.
Zero	Input for setting a zero point anywhere within the encoder resolution. The zero setting operation is triggered with Vs.
Direction	UP/DOWN counting direction input. This input is standard on High. UP/DOWN means ascending output data with clockwise shaft rotation when looking at flange.

#### Encoder Part Number

