

Absolute encoders - SSI / BiSS

Shaft with clamping or synchro flange
Single turn 12...19 bit,
Multi turn 4...32bit



FNC AS 58S SS Series



Features

- Encoder single - or multiturn / SSI - BiSS
- Magnetic Sensing (Optional optical sensing)
- Optical Single turn Resolution: 12...19 bit
- Magnetic Single turn Resolution: 9...13bit
- Multi turn 4...32bit
- Clamping flange or synchro flange
- Permanent check of code continuity
- Extreme resistance to shock and vibration
- Encoder with electronic reset

Technical data - electrical ratings

Voltage supply	5.5VDC to 30VDC 4.75VDC to 5.5VDC
Protection:	Output short circuit protection. Reverse polarity protection (except 5V version)
Consumption w/o load	≤50 mA (24 VDC)
Interface	SSI or BiSS
Resolution (steps/turn)	Magnetic: 14 bit Optic: 21 bit
Absolute accuracy	Magnetic: ±0,1° Optic: ±0,01°
Optoelectronic life time	100.000 (min)
Code	Gray or binary
Inputs	SSI differential clock Direction Electronic zero setting Chip select (Optional)
Output frequency	up to 2MHz (SSI) up to 10MHz (BiSS)
Output circuit	SSI data linedriver RS485
Interference immunity	DIN EN 61000-6-2
Emitted interference	DIN EN 61000-6-4
Approval	CE

Technical data - mechanical design

Dimensions (flange)	ø58 mm
Shaft loading	≤140 N axial ≤240 N radial
Protection DIN EN 60529	IP 67
Operating speed	≤10000 rpm
Starting torque	≤0.025 Nm (IP 67)
Materials	Housing: Stainless steel Shaft : Stainless steel
Shaft diameter:	6, 8, 10, 12 mm (other diameters on request)
Bearings lifetime:	2x10 ⁹ rev. at 100% of full rated shaft load (minimum)
Operating temperature	-40...+110 °C -40 °C up to +120 °C (Storage)
Weight approx.	250 g

Pulse Diagram

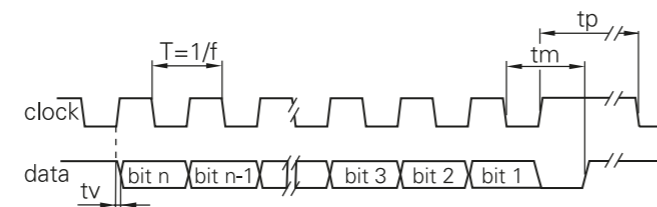

Clock frequency, f	50...2000 kHz for SSI up to 10MHz for BiSS
Code	Binary or gray
Status and parity bit	On request
Monoflop time tm	>15µs
Clock time out	Programmable at factory

Absolute encoders - SSI / BiSS

Mechanical Dimensions
Cable/Connector Wiring, Part Number



FNC AS 58S SS Series

Mechanical Dimensions

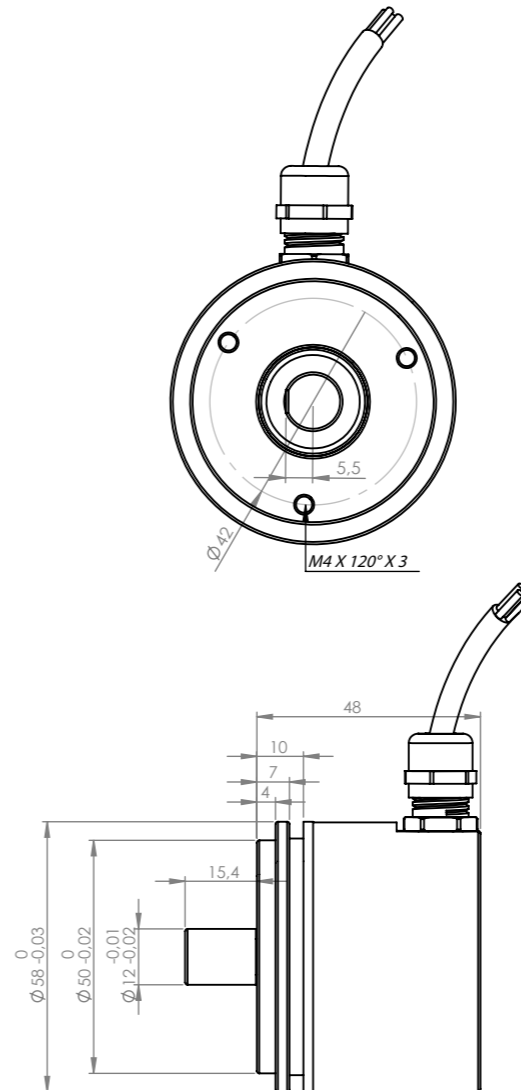

Cable / Connector M23 male

Connector	Core colour	Signals	Description
Pin 1	blue	Clock+	Clock signal
Pin 2	blue-black	Clock-	Clock signal
Pin 3	orange	Data+	Data signal
Pin 4	orange-black	Data-	Data signal
Pin 5	gray	Zero	Zero setting input
Pin 6,7,8,9	-	n.c.	-
Pin 10	gray-black	up/down	direction input
Pin 11	white	0 V	GND
Pin 12	brown	+Vs	Supply voltage

Screen: not connected to housing
Cable data: 4 x 2 x 0.14 mm²

Terminal significance

+Vs	Encoder supply voltage.
0 V	Encoder ground connection relating to +Vs.
Data+	Positive data output.
Data-	Negative data output.
Clock+	Positive SSI clock input.
Clock-	Negative SSI clock input.
Zero	Input for setting a zero point anywhere within the encoder resolution. The zero setting operation is triggered by a Low impulse. Connect to +Vs after setting operation for maximum interference immunity. Impulse duration >2 ms.
Note	Include termination resistor R=120 Ohm between Data+ and Data- on control side.
Direction	UP/DOWN counting direction input. This input is standart on High. UP/DOWN means ascending output data with clockwise shaft rotation when looking at flange.

Encoder Part Number

FNC **A** **S** **O** **58** **S** **SS** **10** **S12** **M12** **30V** **B** - **R2**

Absolute	
S : SSI B : BiSS	
O : Optical M : Magnetic	
Housing: 58 : 58mm	
Flange Type: S : Servo flange B : Clamping flange	
SS : Stainless Steel	
Shaft diameter : 6, 8, 10, 12 Other dimensions on request	

Electrical Connections:

Cable
R2 : radial 2m A2 : axial 2m

Connector:
R1212 R2312L R2312R

B: Binary **G**: Gray

Supply Voltage:
5V : 5V in / out 30V : 5-30V in / out

Multi turn options: 4, 8, 12, 16, 20, 24, 32

S: Single Turn
up to 21 bit