

Absolute encoders - SSI / BiSS

Singleturn up to 20 bit

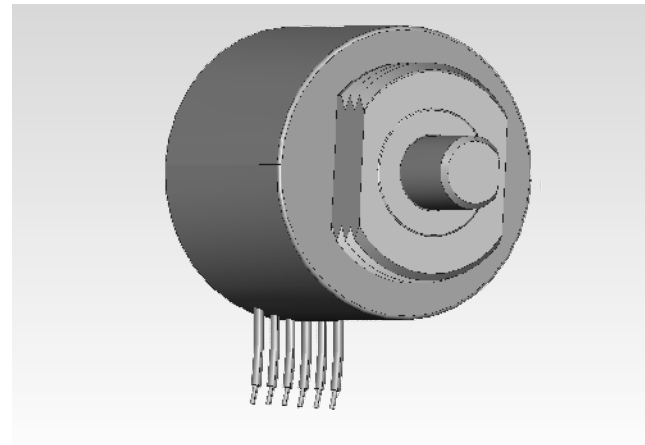

FNC AS 16SV Series, Screw Type Micro Encoder



Features

- Encoder singleturn SSI/BISS
- Magnetic or optical sensing
- Singleturn resolution up to 20 bit
- Clamping flange or synchro flange
- Permanent check of code continuity
- Extreme resistance to shock and vibration
- Encoder with electronic reset

Technical data - electrical ratings

Voltage supply	5VDC
Protection:	Output short circuit protection. Reverse polarity protection (except 5V version)
Consumption w/o load	≤80 mA (24 VDC)
Interface	SSI or BiSS
Resolution (steps/turn)	20 bit
Absolute accuracy	Magnetic: ±0,1° Optic: ±0,01°
Optoelectronic life time	100.000 (min)
Code	Gray or binary
Inputs	SSI differential clock Direction Electronic zero setting
Output frequency	up to 2MHz (SSI) up to 10MHz (BiSS)
Output circuit	SSI data linedriver RS485
Interference immunity	DIN EN 61000-6-2
Emitted interference	DIN EN 61000-6-4
Approval	CE

Technical data - mechanical design

Dimensions	ø16 mm
Shaft loading	≤20 N axial ≤40 N radial
Protection DIN EN 60529	IP 65
Operating speed	≤10000 rpm
Starting torque	≤0.001 Nm (IP 67)
Materials	Housing, Flange : Aluminium Shaft : Stainless steel
Shaft diameter:	4 mm
Bearings lifetime:	2x10 ⁹ rev. at 100% of full rated shaft load (minimum)
Operating temperature	-40...+90°C -40 °F ... +180 °F
Weight approx.	250 g

Pulse Diagram

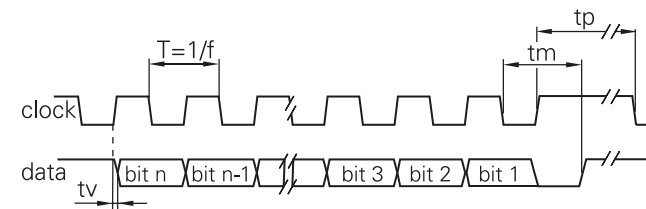

Clock frequency, f	50...2000 kHz for SSI up to 10MHz for BiSS
Code	Binary or gray
Status and parity bit	On request
Monoflop time tm	>15µs
Clock time out	Programmable at factory

Incremental encoders

Mechanical Dimensions
Cable/Connector Wiring, Part Number



FNC AS 16SV Series, Screw Type Micro Encoder

Mechanical Dimensions

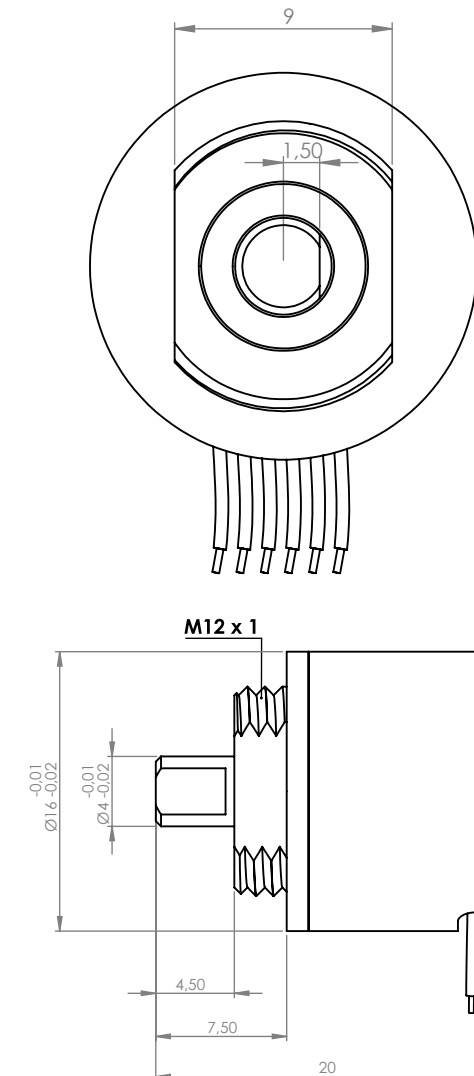

Terminal significance

+Vs	Encoder supply voltage.
0 V	Encoder ground connection relating to +Vs.
Data+	Positive data output.
Data-	Negative data output.
Clock+	Positive SSI clock input.
Clock-	Negative SSI clock input.
Note	If needed, Include termination resistor R=120 Ohm between Data+ and Data- on control side.

Connector	Core colour	Signals	Description
Pin 1	blue	Clock+	Clock signal
Pin 2	blue-black	Clock-	Clock signal
Pin 3	orange	Data+	Data signal
Pin 4	orange-black	Data-	Data signal
Pin 6,7,8,9	-	n.c.	-
Pin 11	white	0 V	GND
Pin 12	brown	+Vs	Supply voltage

Screen: not connected to housing
Cable data: 4 x 2 x 0.14 mm²

Encoder Part Number

FNC **A** **S** **O** **16** **SV** **4** **S12** **5V** **B** - **R4**

Absolute	
S : SSI B : BiSS	
O : Optical M : Magnetic	
Housing 16 : 16mm	
Flange Type : SV : Screw type	
Shaft diameter : 4 mm Other dimensions on request	
Electrical Connections:	
Cable R4: radial 4m R1C4: connector after 1m Cable	
Connector: R1214 R2312L R2312R	
B : Binary G : Gray	
Supply Voltage: 5V : 5V	
S : Single Turn up to 20 bit	