

FNC 58E 100 BHF Series

Special Design for textile industry
Special Design for Reiter machines



Features

- Industry 58 mm standart size, end hollow shaft
- Robust mechanical and electrical construction
- Protection to IP67
- 100 or 200 PPR options
- <300 kHz frequency

PPR Options :

100 PPR
200 PPR

Technical data - electrical ratings

Voltage supply	4.75VDC to 30VDC 4.75VDC to 5.5VDC
Protection:	Output short circuit protection. Reverse polarity protection (except 5V version)
Consumption w/o load	≤60 mA (24 VDC)
Resolution (steps/turn)	1...25.000
Reference signal	Zero pulse, width 90° 180°, 360° optional
Optoelectronic life time	100.000 (min)
Output frequency	>200 kHz
Output signals	90° shifted A and B, Z + inverted
Output circuit	Linedriver/RS422 Push-pull short-circuit proof
Interference immunity	DIN EN 61000-6-2
Emitted interference	DIN EN 61000-6-4
Approval	CE

Technical data - mechanical design

Dimensions (flange)	ø58 mm
Shaft loading	≤140 N axial ≤240 N radial
Protection DIN EN 60529	IP 67
Operating speed	≤10000 rpm
Starting torque	≤0.025 Nm (IP 67)
Materials	Housing: Aluminium Flange: Aluminium Shaft : Stainless steel
Shaft diameter:	6, 8, 10, 12, 14, 15, 16 mm (other diameters on request)
Bearings lifetime:	2x10 ⁹ rev. at 100% of full rated shaft load (minimum)
Operating temperature	-20...+85 °C
Storage temperature	-30 °C up to +90 °C
Weight approx.	250 g

Accessories

Connectors and cables
CRM1607 M16 7 poles female connector or see page 206

Mounting coupling
See page 204

Mounting accessories
NGL spring or see page 202-203

FNC 58E 100 BHF Series

Mechanical Dimensions

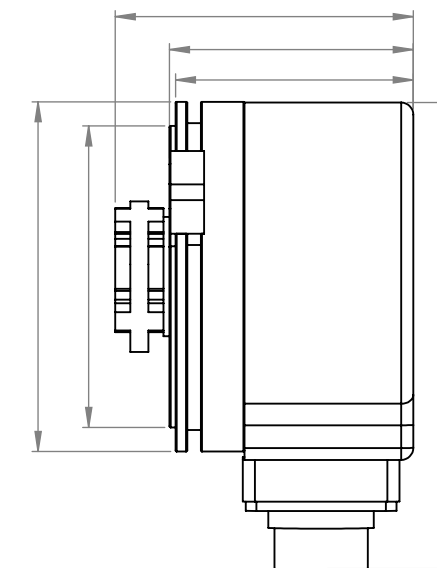
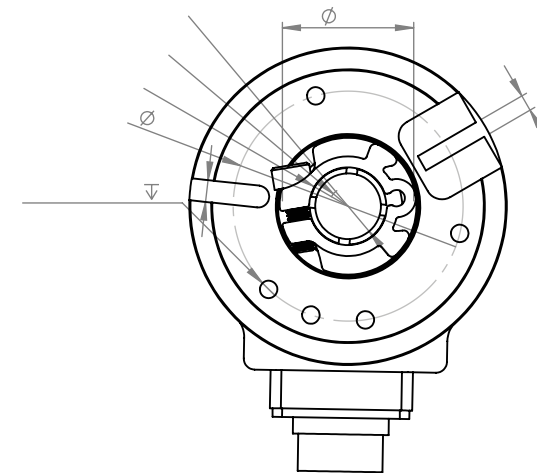

Pulse Diagram

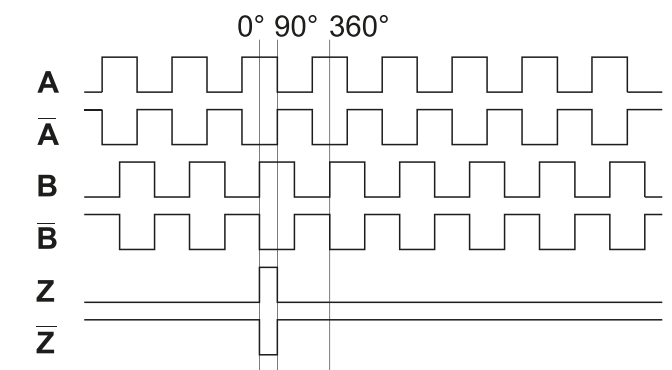

Encoder Part Number

Option 1

FNC 58 E 100 BHF

Option 2

FNC 58 E 200 BHF